

## FUEL FLOW METER AIC - 4004 / 4008 VERITAS

**Diesel consumption flow meter for engines up to 662 KW (900 HP)  
Permanent mounting system, ideal for fleet management systems**

888  
Instruktor

900  
Veritas

1000

4000  
Veritas

5000  
Fuel flow  
Master

6000  
Swissline

FS

Board  
Computer  
and  
Totalizer



The AIC-4000 VERITAS flow meter has been designed for a permanent mounting for the fleet management whereas the instantaneous, average and cumulated values can be monitored.

Made for pulsating liquids, the true consumption of the vehicle engine is measured by switching the return flow from the tank, directly to the fuel supply line.

### Application

- Medium and large trucks, buses, building machines, tractors, boats, etc.

### Media that can be measured

- any fuel oil

### Features and benefits

- **Up to 15 % of fuel economy, through a constant control of the driver**
- Reliable instantaneous consumption display and flow totalization
- **Average fuel consumption visualisation with 3 digits after coma**
- Instrument protected via in-line fuel filter
- Mechanical meter of proven technology since more than 20 years
- No interferences with vehicle existing on-board electronic (CAN-Bus)
- AIC flow meters works on all fuel injection type (except systems with open injectors, Cummins HPI)
- Suitable for engines with fuel injection of latest generation

CE certified  
EME Test according  
to 95/54/CE directives

## Measuring Systems

A complete measuring systems consist of :

- flow meter AIC-4004 or 4008
- fuel oil filter (included)
- board computer BC 3034
- cables for electrical connection (included)
- couplings for installation



## Measuring principle

Each unit is produced as one module in the interests of simple installation. All holders and housing parts are made of stainless steel or anodized aluminium.

### Fuel flow measurement:

The consumption of fuel for engines can be measured by 2 ways :

- Direct (means that there is no fuel returning to the tank, the return flow is reinjected in the fuel circulation flow of the injection circuit.
- Differential (means that the supply and return flow are subtracted. The return fuel flow goes back in the tank.

AIC SYSTEMS Ltd. has strongly developed the best measuring solution : the **DIRECT flow** measurement. This solution allows a true measurement of the fuel flow, within a uncertainty better than +/- 1 % (+/- 0.2 % repeatability). The differential fuel flow allows only an accuracy of best 5 % or worse.

### High pulse rate output:

The control and pulse technology is based on the latest SMD technology and is moulded to be water tight and vibration resistant (Pat. AIC). This allows high pulse count per flow quantity unit. The AIC-4004 VERITAS is supplied with 2000 ppl, and the AIC-4008 VERITAS with 804 ppl (pulses per one litre).

### Rotary piston technology:

After decades of experience, AIC SYSTEMS Ltd. make has opted for the reliable volumetric flow meter technology. The rotary piston technology fits the fuel consumption measuring principle ideally. A single moving piston oscillates softly in a measuring chamber protected by a thin layer of fuel maintaining the piston self floating. This allows the meter to have the less possible mechanical friction, thus reduced wear. Under normal working conditions the pressure loss ahead of the measuring cell is of max. 100 mbar.

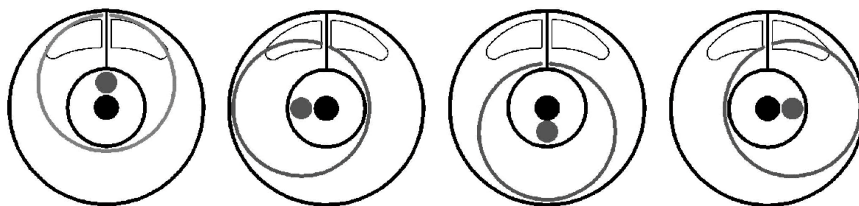

## Calibration

Each flow meter unit, is subject to careful calibration at the factory. Customer calibration can also be saved on simple demand.

# Dimensions

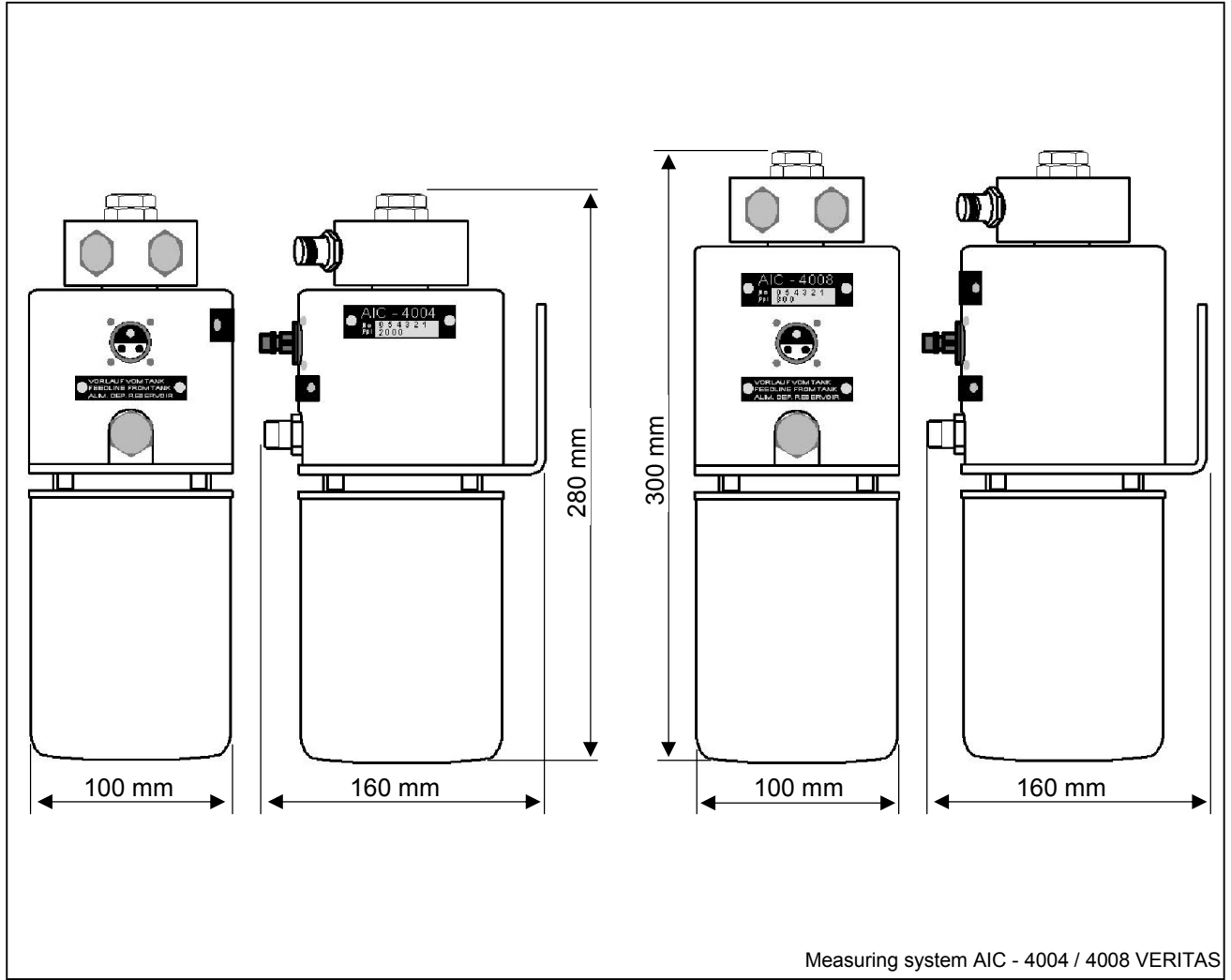

# Installation

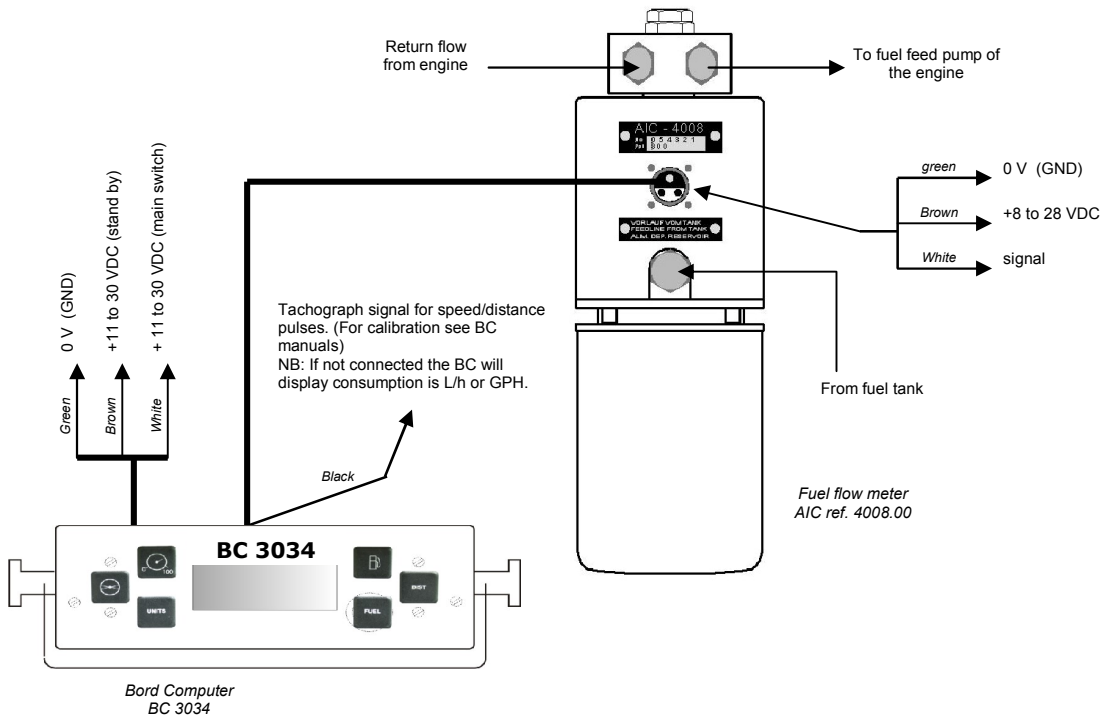

## Technical data

### AIC 4004 et 4008 VERITAS

#### General data

Manufacturer	AIC SYSTEMS S.A.
Product designation	AIC-4004 VERITAS AIC-4008 VERITAS AIC-4008 S VERITAS

#### Mechanical data

Dimensions (L x l x p)	AIC-4004 280 x 100 x 160 mm (incl. filter) AIC-4008 / AIC-4008 S 300 x 100 x 160 mm (incl. filter)
Weights	AIC-4004 2,5 kg (incl. filter) AIC-4008 / AIC-4008 S 2,8 kg (incl. filter)

#### Materials

Flow meter sensor	Brass, aluminium
O-rings	Viton®
Connectors	Steel protection TAAC3, stainless steel, anodised aluminium
Casing	Anodised Aluminium
Mounting bracket	Stainless steel

#### Flow meter

Measurement Principle	Volumetric, oscillating piston, with microprocessor controlled pulse emitter (Pat. AIC)
Measuring range	AIC-4004 : 1 to 80 l/h AIC-4008 : 4 to 200 l/h AIC-4008 S : 4 to 240 l/h
Accuracy	better than 1 % of reading
Repeatability	better than 0.2 % of reading
Admissible pressure	- 1 to 6 bar
Mounting position	Vertical
Operating temperature	-30 ... 90°C
Ingress protection	Sensor and electronic, IP 67

#### Electrical connection

Power supply	11 - 28 VDC
Pulse signal	rectangular NPN, open collector, pulse width 0.6ms
Pulse rate	AIC-4004 : 2000 ppl AIC-4008 : 804 ppl AIC-4008 S : 804 ppl

## Ordering structure

### Flow meter

<b>Model Type</b>	<b>Designation</b>	<b>Order code</b>
AIC-4004 VERITAS	for engines up to max. 220 KW (300 HP) 2000 ppl, pulse rectangular, NPN open collector, pulse width 0.6 ms	S4004.00
AIC-4008 VERITAS	for engines up to max. 515 KW (700 HP) 804 ppl, pulse rectangular, NPN open collector, pulse width 0.6 ms	S4008.00
AIC-4008 S VERITAS	for engines up to max. 662 KW (900 HP) 804 ppl, pulse rectangular, NPN open collector, pulse width 0.6 ms	S4008S.00

### Accessories

Connection kit	Universal connection kit CS-1, includes various connection fitting (metric), fuel hose not included	S1450.1
Fuel hose	Fuel hose UNIPRESS 9.5 x 18 mm, NBR reinforced (not for Bio-diesel purposes)	S1440.0
	Bio-Diesel fuel hose 10x 14 mm, PUR reinforced	S1540.0
Connection cable	10 m cable connecting the fuel oil meter to the Board Computer BC 3034	5610.10
	10 m cable connecting the fuel oil meter with wires end free	5620.10
Thief proof protection	4 pcs, shrinking hose, 1 pc hose clip	S1475.0

### Board Computers

<b>Model Type</b>	<b>Designation</b>	<b>Order code</b>
BC-3034	on-board computer, incl. 14 functions and data logging option. and programming plug. Operating voltage : 11 to 30 VDC Functions available : consumption-instantaneous, -average with 3 decimals, -cumulated, travel speed, distance travelled, average speed, cumulated fuel consumption, driving time, operating time Choice of standards : metric, US	S3034.00



AIC SYSTEMS AG.  
Ringstrasse 9,  
CH - 4123 Allschwil  
**Switzerland**

T +41 61 481 84 39  
F +41 61 481 84 40

[www.flowmeter-aic.com](http://www.flowmeter-aic.com)  
[info@flowmeter-aic.com](mailto:info@flowmeter-aic.com)